

Product:
KODAK DL2100 Duplex Printer

Announcement Date:
January 31, 2008

Launch/Initial Shipments:
Summer, 2008



Value proposition:

The KODAK DL2100 Duplex Printer is an on-site electro-photographic printer optimized for use with the KODAK Adaptive Picture Exchange (APEX) and KODAK Picture Kiosks that lets retailers participate in the \$16B greeting card and photo book categories and significantly grow their business. It provides the option for photo gifts in-store while the customer waits or for pick-up (later) and is priced to generate pay back in less than one year.

Key Features:

- Prints up to 13 duplex pages per minute - most photo books will print in less than 3 minutes
- Enables duplex printing of Kodak 148 gsm – 216 gsm papers and card stocks
- Orders entered utilizing our award-winning and easy-to-use Kiosk workflow software
- Provide Kodak quality output using Kodak Perfect Touch Technology
- Installable into an APEX back lab system or directly into a KODAK Picture Kiosk Order Station
- Designed to take advantage of future 3rd party branded content to enhance profit potential
- Uses LED technology with a Light Emitting Diode print head as a light source within the imaging device. Unlike laser systems, the LED print head is solid-state and has no complicated rotating mirrors.
- Printer has Advanced Unit Replacement serviceability (varies by region)

Contents:

- DL2100 Printer with duplexer
- 4-color toner set
- Second paper input tray
- USB cable
- Power cord (US and EAMER)
- Kiosk enablement CD
- User manuals

Target Audience:

- Retailers that want to offer additional value added service by offering on-site duplex photo gifts for their customers – while they wait or for later pick up.

Consumer Products:

- Creates 8 ½ x 11 inch / A4 size two sided photo books - up to 30 pages
- Creates 8 ½ x 11 inch / A4 size calendars with writeable media
- Creates folded 5x7 inch greeting cards in landscape or portrait formats with customizable images, graphics and using writeable media

Specifications:

Item	Specification*
Printer	KODAK DL2100 Duplex Printer: Single Pass LED, 1200x600 dpi, Electro-photographic Printer
Processing	500Mhz, 64 bit, 256 MB memory
Print Times	First color print in 11 seconds. Up to 13 duplex sheets per minute
Media	148 gsm 8 ½ x 11 inch & A4 Coated Paper, Packs of 250 Sheets 216 gsm 7x10 inch Coated Card Stock, Pre-Scored, Packs of 250 Sheets
Toner	Separate Toner: Cyan, Magenta, Yellow and Black ~ 1,300 pages/cartridge Separate Imaging Drum: Cyan, Magenta, Yellow and Black ~ 20,000 pages per drum (sold separately)
Size (WxDxH)	17.1x24.3x19.4" (43.5x61.8x49.3 cm)
Weight	Approx.74 lb. (33.5 kg)
Power Consumption	Separate models: 120 VAC or 230 VAC - Energy Star Compliant

*Preliminary - subject to change

Kodak contact(s):

Nancy Carr (Media)
WW Public Relations
585-781-9121
nancy.carr@kodak.com

Colleen Krenzer (Media)
Ketchum
646-935-4377
Colleen.Krenzer@ketchum.com

SPECIFICATIONS
for the
***Kodak* DL2100 DUPLEX PRINTER**
Service Code: 8712

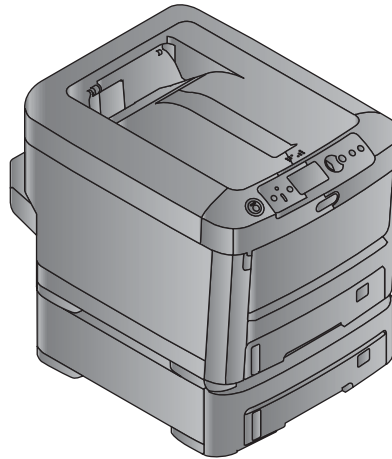

A172_0048AA

PLEASE NOTE The information contained herein is based on the experience and knowledge relating to the subject matter gained by Eastman Kodak Company prior to publication.

No patent license is granted by this information.

Eastman Kodak Company reserves the right to change this information without notice, and makes no warranty, express or implied, with respect to this information. Kodak shall not be liable for any loss or damage, including consequential or special damages, resulting from any use of this information, even if loss or damage is caused by Kodak's negligence or other fault.



This equipment includes parts and assemblies sensitive to damage from electrostatic discharge. Use caution to prevent damage during all service procedures.

Table of Contents

Description	Page
Equipment Specifications	3
Size and Weight	3
Packed	3
Unpacked	4
Site Specifications	5
Space Requirements	5
Power Requirements	6
Environment Requirements	6
Requirements for Storing the Consumables	6

Section 1: Equipment Specifications

Size and Weight

Packed

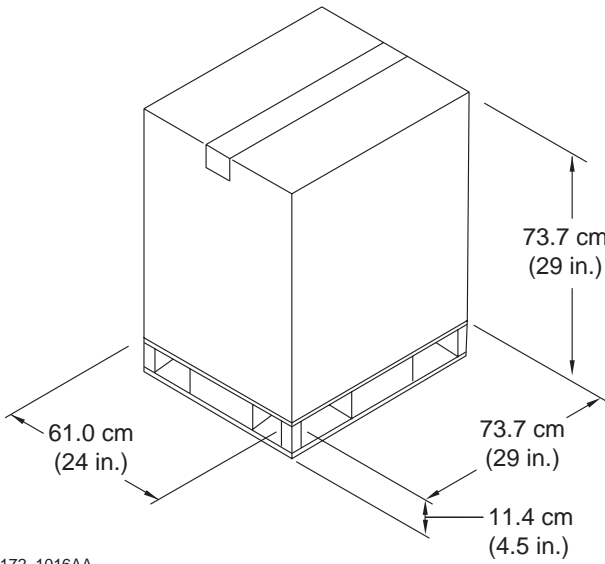

A172_1016AA

Height:	73.7 cm (29 in.)
Width:	61.0 cm (24 in.)
Depth:	73.7 cm (29 in.)
Pallet Height:	11.4 cm (4.5 in.)
Weight:	33.0 kg (72.8 lb)

Unpacked

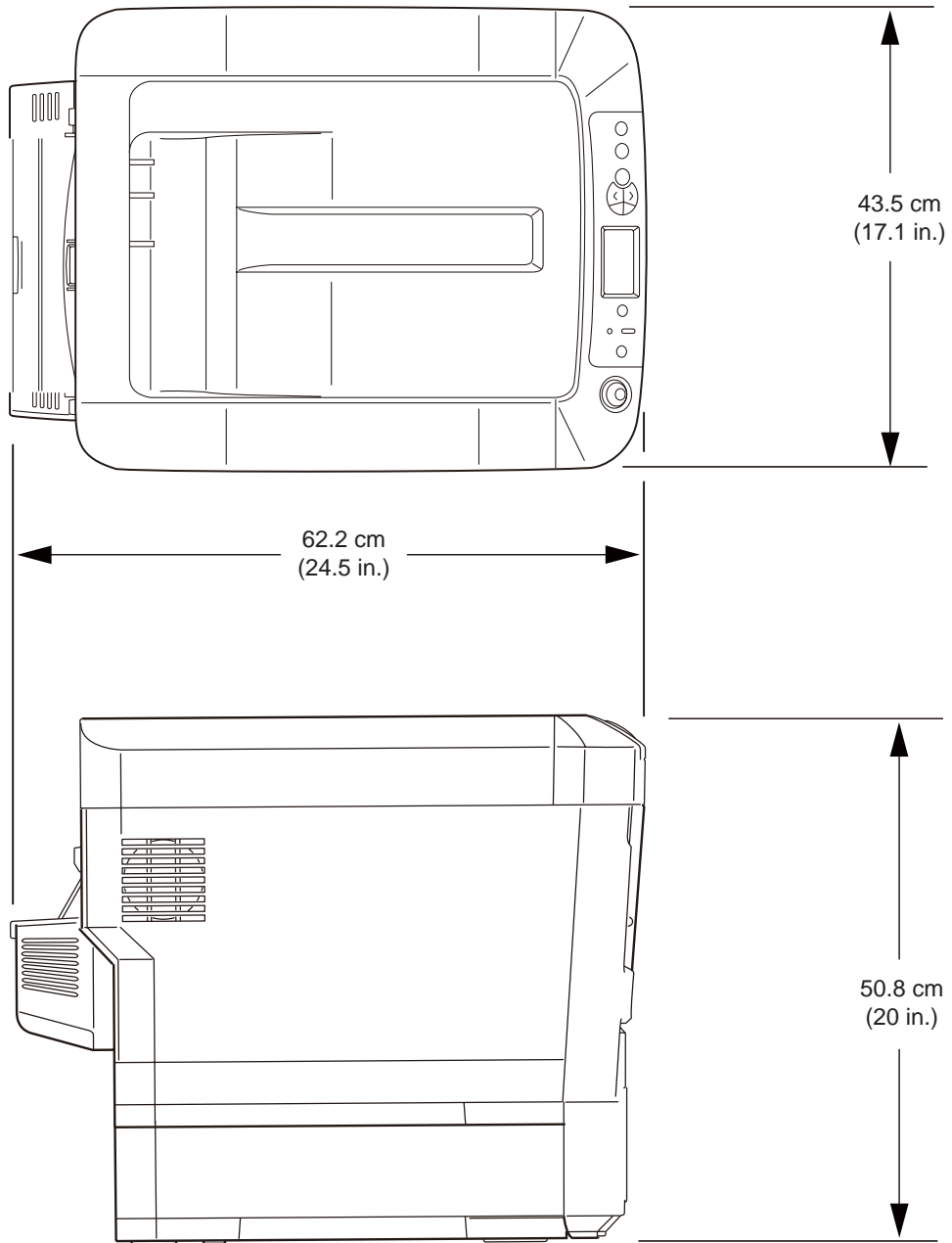

A172_1014DA

- Height:** 50.8 cm (20 in.)
- Width:** 43.5 cm (17.1 in.)
- Depth:** 62.2 cm (24.5 in.)
- Weight:** approximately 31.0 kg (68.3 lb)

Section 2: Site Specifications

Space Requirements

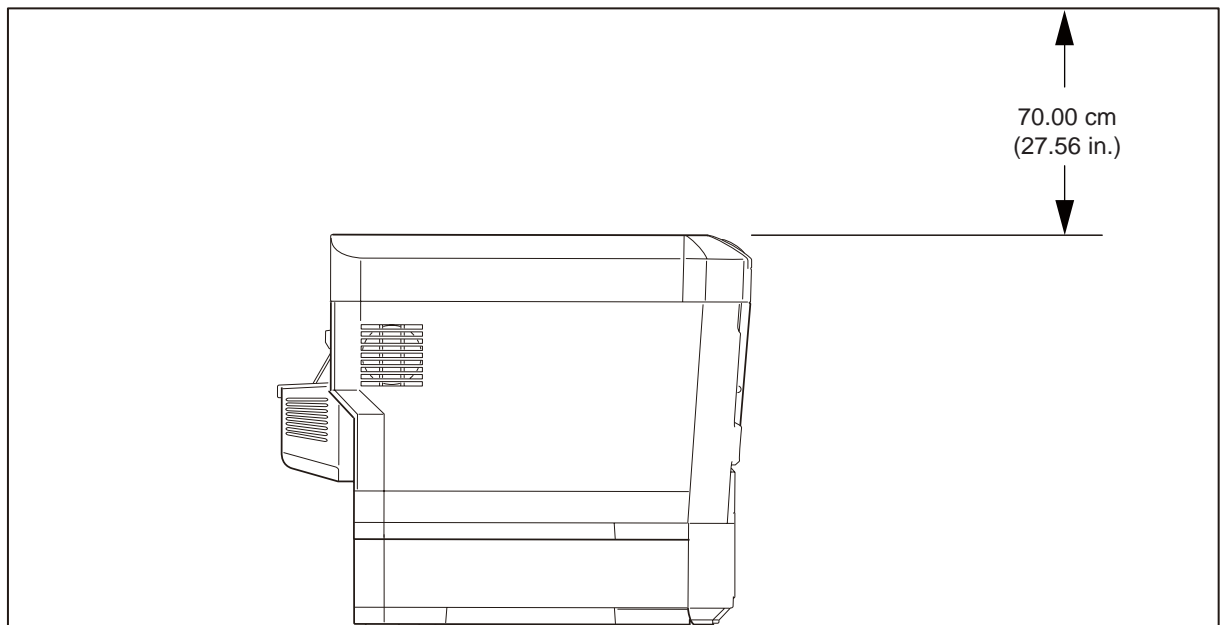
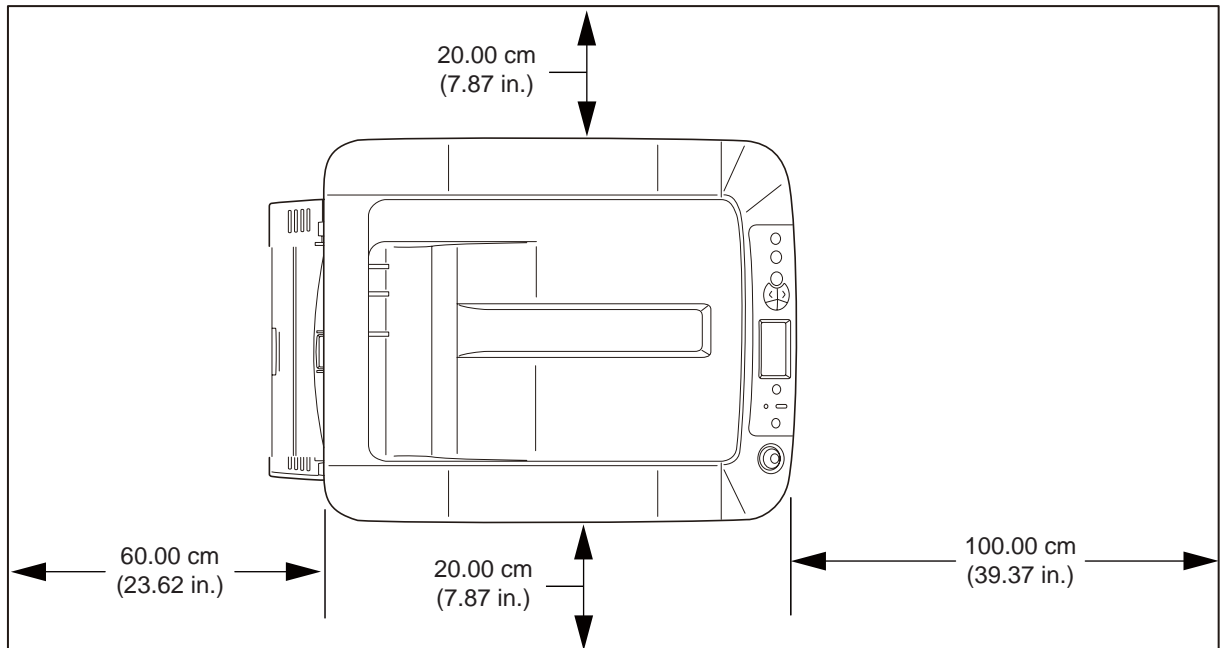

A172_1015DA

Right Side:	20.00 cm (7.87 in.)
Left Side:	20.00 cm (7.87 in.)
Front:	100.00 cm (39.37 in.)
Back:	60.00 cm (23.62 in.)
Top:	70.00 cm (27.56 in.)

Power Requirements

The PRINTER has an auto-detecting power supply.

Voltage	Power Consumption	Frequency
100 V AC \pm 10 %	<ul style="list-style-type: none"> • Normal: 530 W depending on operating environment • Maximum: 1200 W • Standby: 100 W • Power save: Less than 17 W 	50 / 60 Hz \pm 2 Hz

Environment Requirements



Important

Do not install the PRINTER in direct sunlight.

Ambient Operating Temperature: 10 – 32°C (50 – 90°F)

Relative Humidity: 20 – 80% non-condensing

Requirements for Storing the Consumables

Consumables	Specification
Toner Cartridge	<ul style="list-style-type: none"> • -10 – 43°C (14 – 109°F) • 10 – 90% (non-condensing) relative humidity
Paper	<ul style="list-style-type: none"> • -5 – 30°C (40 – 85°F) • 20 – 70% (non-condensing) relative humidity • Do not store in direct sunlight

Kodak is a trademark of Eastman Kodak Company.